



The fume cupboard GS1000/Standard



Technical features

The GS series bench-type fume hoods are safety devices able to protect laboratory operators from the risk of inhaling harmful volatile chemicals directly recycling the laboratory air with a filtration system. These devices are able to be installed in any working environment, to capture and eliminate harmful volatile substances at source, in accordance with legal requirements.

The molecular air filtration process takes place through an adsorption process in size "B" (450x600x100 H mm) highly efficient activated or impregnated carbon filters. Preliminary filtration to remove dust has carried on with one or more size "B" (450x600 mm) dust cover. The unit is also able to equip additional safety filters downstream of the main filter.

The filtered air extracted by GS series fume cupboards can be recycled without affecting the operation of the air handler (HVAC) or it could be exhausted outside of the building by means of the 250mm diameter manifold supplied as standard.

Routine inspection and replacement of the filter and pre-filter are extremely simple and safe.

GS-series fume cupboards frame is manufactured with epoxy polyester (colour RAL7035) coated steel plate and epoxy paint finished aluminium uprights (colour RAL7015). The sides and front sash are in 3 mm layered safety glass.

They are fitted as standard with an electronically controlled centrifugal fan. The internal back baffle is manufactured in 6mm thick acid-resistant white laminate.

All our GS series fume cupboards comply with:
-CE Mark under 2006/42/EEC Machinery Directive
-2006/95/EEC Low Voltage Directive

COMFIT srl
Via Viberti, 4
10141 Torino TO
Tel. +39011720085
Fax.+39011728870
comfit@tiscali.it
www.comfit.org

Subject to change without notice the technical characteristics of the products shown. All rights reserved. COMFIT sas. 05/2014

Aria nuova in laboratorio...

-2004/108/EEC Electromagnetic Compatibility Directive
-CEI EN 61010 -1 Prescriptions regarding the safety of electrical measurement, control and laboratory equipment, Classification C.E.I.66.5

It is certified from Invent UK Ltd, Imperial College London (UK) under:

- BS7258, certificate test report number INV/BS7258/261
- DIN 12924, certificate test report number INV/DIN12924/261
- ANSI/ASHRAE 110/1995, certificate test report number INV/ASHRAE 110/263
- BS7989/2001, certificate test report number 13/02

The filters are certified with regard to various types impregnated under BS7989/2001 (in accordance with the standard for the specific application), with tests demonstrating an efficiency of 99%.

Finally the whole GS series comply with EN14175 tests with result:

- Inner Plane EN 14175-3:2003-section 5.2.6.1: concentration lower than 0.1 ppm
- Outer Plane EN 14175-3:2003-section 5.2.6.2: concentration lower than 0.2 ppm
- Robustness of containment EN 14175-3:2003-section 5.3: containment factor of 230 with a front speed of 0.4 m/sec.

STANDARD: with the general characteristics described above and with our "TIMELOG" electronic device for continuous monitoring. The TIMELOG control and monitoring device, installed on the fume cupboard's right-hand upright, include a touch screen display for setting operational parameters and reading alarm messages.

The cupboard could be powered up with an On-Off thermal switch.

The TIMELOG display through a sequence of screens supplies to the user:

- Fume cupboard Model and Serial Number
- Type of filters installed and installation date
- Estimated time left before inspection and/or replacement of the filter(s) installed
- Temperature of air in transit (if the permissible temperature threshold for the type of filter installed is exceeded, an alarm switch on)
- General unit operating hour counter and sash opening height indicator
- Face velocity in "m/sec" and extracted air quantity in "m³/hr"

When appropriate, the above settings trigger a number of safety alarms as required by law (Italian Decree Law 626/94 and further reviews):

- Alarm light and buzzer indicating low face air velocity (with trigger threshold setting)
- Alarm light and buzzer indicating opening of sash beyond safety limit set.
- Alarm light and buzzer indicating expiration of set filter inspection time
- Alarm light and buzzer indicating temperature above set threshold for safe filter operation

The "TIMELOG" electronic system regulates the air flow rate to ensure a constant face velocity by varying the speed of fan speed on a progressive scale in response to even minimal changes in sash opening.

The absolute flow setting can be modified by varying the control parameters to obtain different flow speeds depending on requirements and specific safety regulations.

COMFIT srl
Via Viberti, 4
10141 Torino TO
Tel. +39011720085
Fax.+39011728870
comfit@tiscali.it
www.comfit.org

Subject to change without notice the technical characteristics of the products shown. All rights reserved. COMFIT sas, 05/2014

Aria nuova in laboratorio...

The fume cupboard is supplied complete with Operator's Manual and Safety Log Book in Italian, for recording routine inspections. Certification of conformity with the relevant directives (CE marking).

GS1000 Standard: with the general characteristics described above and equipped with

- Hour meter for maintenance operations
- low face air velocity alarm
- Ducting fitting supplied as standard

Sash maximum opening: W 780 x H 750 mm

Sash working condition opening (BS 7258 prescription): W 780 x H 400 mm.

Side walls in laminated glass + 0.38 mm 3 + 3 PVUB uprights in extruded aluminum.

Double bottom inner laminate thickness 6 mm antacid white.

Work surface made as a removable autoclave-ready tray with fluid containment rim (capacity 10 L/m²) in AISI 304 stainless steel for maximum cleaning.

Power supply: 230 Volts - 50/60 Hz - 3.2 A

Internal lighting with airtight lamp IP55, V 220-230, W 2x18 - Luminance Lux 1000

Noise level: acoustic pressure below 58 dBA

Mean face velocity: 0.5 m/sec

Extraction fan: 1x EC centrifugal brushless fan

Prefilter (600 x 450) mm: 1x size "B"

Main filter (600 x 450 x 100) mm: 1x size B activated / impregnated carbon filter

External dimensions (wxdxh): 1000 x 750 x 1500 mm

Internal dimensions (wxdxh): 950 x 600 x 750 mm

Weight: 130 kg

The fume cupboard is supplied complete with Operator's Manual and Safety Log Book in Italian, for recording routine inspections. Certification of conformity with the relevant directives (CE marking).

Technical dimensions sheet

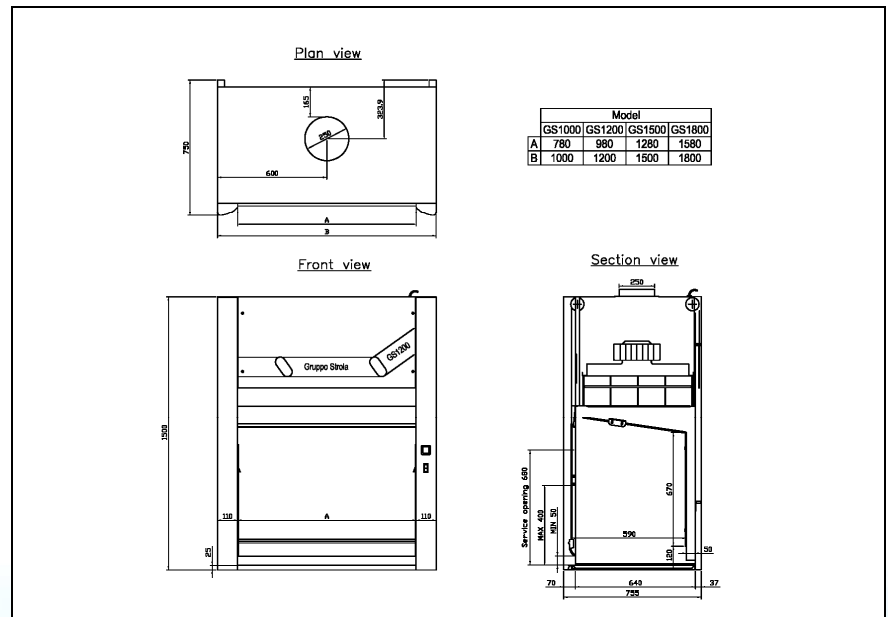

COMFIT srl
 Via Viberti, 4
 10141 Torino TO
 Tel. +39011720085
 Fax. +39011728870
 comfit@tiscali.it
 www.comfit.org

Subject to change without notice the technical characteristics of the products shown. All rights reserved. COMFIT sas, 05/2014

Aria nuova in laboratorio...